

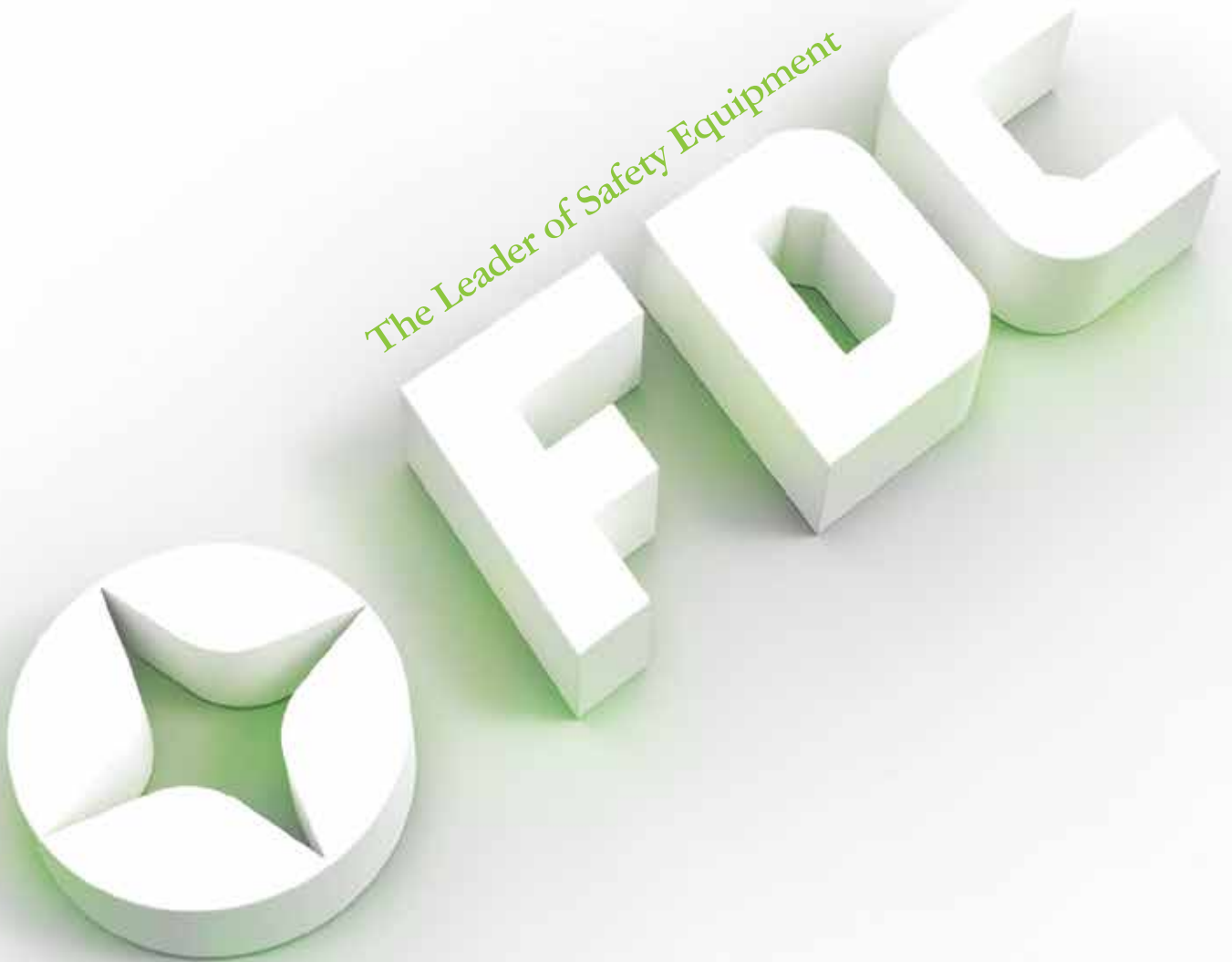


PRESSURE / / SAFETY DEVICES

RUPTURE DISC / EXPLOSION PANEL

N2 BLANKETING SYSTEM / EMERGENCY RELIEF HATCH

The Leader of Safety Equipment



www.finedisc.co.kr



***FDC Small but strong
enterprise in the world!***

04 CEO MESSAGE	16 PRODUCTIONS
06 COMPANY HISTORY	26 RUPTURE DISC - MODEL - SPECIFIC FEATURES
07 CERTIFICATION	33 BURST SENSOR
08 INTRODUCTION OF RUPTURE DISC	34 RUPTURE DISC - ACCESSORY
10 KOSHA OBLIGATORY SAFETY CERTIFICATION	35 EXPLOSION PANEL
12 SELECTION GUIDE OF RUPTURE DISC	36 N2 BLANKETING SYSTEM
13 SELECTION MODEL OF RUPTURE DISC	37 EMERGENCY RELIEF HATCH
14 CALCULATION OF RUPTURE DISC SIZE	



CEO MESSAGE

FDC is a leading company that has succeeded in localization of Rupture Discs for the first time in Korea. We are competing against excellent companies of the world on the basis of the know-how accumulated from production of Rupture Discs over the past 25 years. We manufacture the complete Rupture Discs in accordance with KS B ISO 4126/6718, KOSHA, ASME Code Sec. VIII and ISO-9001:2008 quality system.

We constantly research and develop new products to improve the quality so to enable us to protect our customer's cherished properties and lives from hazards such as explosions.

Our business includes Rupture Discs, Explosion Panels, N2 Blanketing System and Emergency Relief Hatch. These products have been applied to pressure safety device in various fields including low pressure storage tank, pressure tank, industrial plants, reactors and ships. We are, in addition, involved in the National Defense Industrial Products development project and recognized the performance and the quality.

We will make it our highest priority that customer's safety and quality assurance, and do our best to be your good partner.

We will keep nation's pride in the pressure safety device field, through Rupture Discs manufactured by FDC.

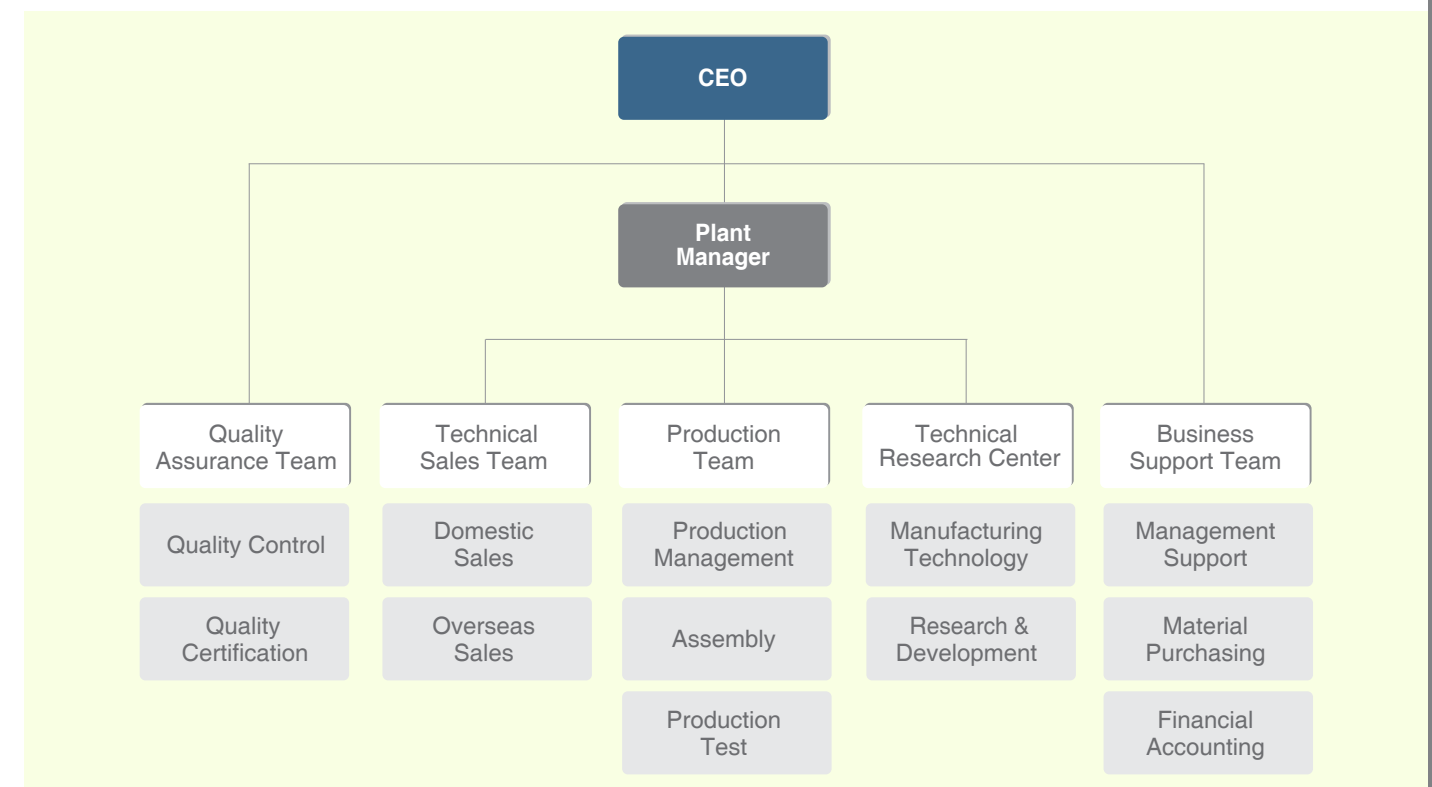
Chief Executive Officer
Yune Ha-won



99, Seobu-ro 1293beon-gil, Juchon-myeon, Gimhae-si, Gyeongsangnam-do, Korea



ORGANIZATION CHART





Building with proud HISTORY

- 2015** Approved vendor for ZADCO, KNPC, KOC and SEC
- 2014** Obtained CSEL (Special Equipment License) Certification in China
Approved vendor for PETRONAS & Saipem
Obtained CE ATEX & IEC EX certification(DUST)
Registered Achilles FPAL
- 2013** Registered a patent for KSRBK Model
Approved vendor for TAKREER & FERTIL & Qatar Petroleum
Obtained CE ATEX & IEC-Ex Certification(GAS)
Obtained ISO 14001, OSHAS 18001 Certification
Received 1 KOSHA Safety Type Certification
Insured Products/Completed Operations Liability Coverage
- 2012** Obtained CE Mark(PED) Certification - EC Type - Examination(Module B)
Received 69 KOSHA Safety Type Certification
Registered as a spare part supplier to KHNP(Korea Hydro & Nuclear Power Co.,LTD.)
- 2011** Obtained CE Mark(PED) Certification - QA System(Module D)
Obtained Russia 'GOST' Certification
Received 6 KOSHA Safety Type Certification extra
Selected as an INNO - BIZ
- 2010** Received 14 KOSHA Safety Type Certification extra
Renamed to FDC Co.,LTD.
Established R&D Center
Won an excellence award from KOSHA Protection Device Quality Award
Participated in Development Project of 20 Core Parts and Materials National Project of the Ministry of Knowledge Economy
Selected as a Patent Star Company - Korean Intellectual Property Office/The Korea Chamber of Commerce & Industry
Appointed as a promising small & medium enterprise for export - Small and Medium Business Administration
Built up the room temperature test facility
- 2009** Received 45 KOSHA Safety Type Certification
Developed Rupture Disc Size Calculation Program
Participated in Development Project of Multi Pulse Rocket Propulsion System - Defense Acquisition Program Administration
Registered as a protection device manufacturer(KOSHA)
Product Liability Insurance - 300 million won
- 2008** Transferred to Fine Disc Co.,LTD.
- 2007** Proceeded Innovative Technology Development Project of small & medium business production environment
- 2006** Accomplished a Technical Development Project of building up the production system for Scored Type for industrial - academic cooperation with Inje University
- 2004** Succeeded in localization of Scored Type Rupture Disc
- 2003** Developed the ultra low pressure Rupture Disc
Consulted on standardization of KS B ISO 6718/4162-2/4162-6
- 2002** Obtained ISO 9001 : 2000 Quality Assurance System
Self - developed N2 Blanketing System
- 2000** Built up the production system of large size Rupture Disc
- 1999** Disaffiliation of Fine Disc focused on Rupture Disc
- 1995** Developed a Rupture Disc Test Program in cooperation with KIMM(Korea Institute of Machinery & Materials)
- 1991** Established Rupture Disc Unit in KOREA STEEL POWER Co.,Ltd.

"FDC would like to jump into a leading position among the world's companies through providing of high quality products, continuous R&D and management innovation"

Registration Certificates



Intellectual Properties



Type Certification of Rupture Disc



KOSHA CE-ATEX IEC-EX CSEL CE-PED GOST

RUPTURE DISC

Introduction

1. What is a Rupture Disc?

- A Rupture Disc is a non-mechanical safety device to relief when it is occurred that excessive pressure is over the critical pressure in a pressure system

2. When is it required a Rupture Disc?

- In case of a rapid rise in pressure as a result of runaway reaction and so on
- In case that there is any concern that fixtures cause other safety device malfunction
- In case that any leakage is not permitted
- In case that it contains strong corrosive fluid
- In case that it requires large relieving capacity in an instant by polymerization and so on
- Severe conditions such as high or low temperature

3. Features

- Special material and structure (It is easy to select material and is economical) And there is no size limit
- Constant rupture performance and release all of fluid
- Instantaneous release of maximum capacity
- Extensive service environment (strong corrosive fluid, temperature, liquid, gas, powder, etc.)
- Zero Leakage
- Extension of safety valve life
- Possible to check the Piping of outlet during operating
- Extension of overhaul period
- Easy to handle and cost reduction

4. Applicable Code

- ASME Sec. VIII Div.1
- ISO 6718
- ISO 4126-2~6
- API RP520
- KOSHA Safety Certification

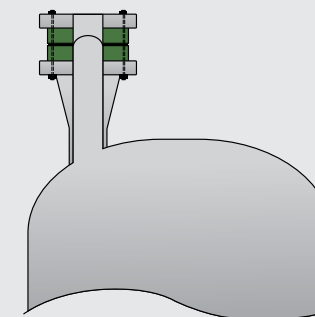
5. Materials of Rupture Disc - Holder / Disc / Accessory

- Stainless Steel (304SS, 316SS, 317SS, etc)
- Carbon Steel
- Duplex
- Aluminum
- Nickel, Inconel, Monel, Hastelloy, Titanium, Tantalum
- Graphite
- Teflon
- Maximum usable Temperature

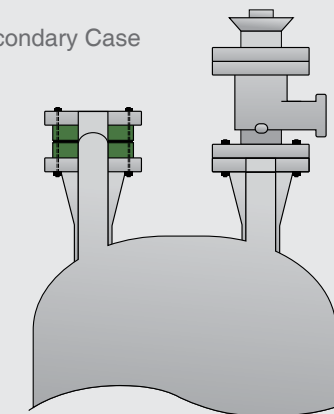
Teflon	200 °C	Monel	483 °C
Aluminum	120 °C	Inconel	592 °C
Stainless Steel	483 °C	Hastelloy	483 °C
Nickel	403 °C	Graphite	371 °C

6. Application of Rupture Disc

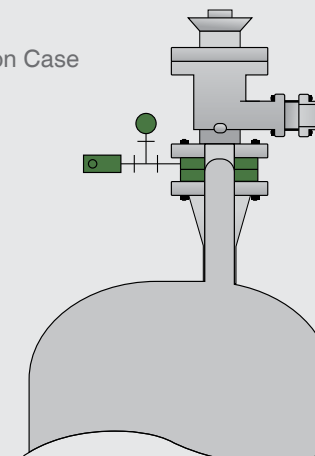
1) Primary Case



2) Secondary Case



3) Combination Case



4) External Fire Case



KOSHA Obligation Safety Certification

1. What is 'Obligation Safety Certification'?

Regarding of manufacture protection devices and protective equipments of hazardous machinery and instrument, it is the system that prevents from industrial accident to produce, distribute and use safe and reliable products by attaching the certification mark to products meet the requirements of safety certification criteria and selling



▶ Korea Obligation Safety Certification Mark

2. Scope of Obligation Safety Certification

Scope of Rupture Discs which are used to protect pressure vessels from overpressure or high vacuum by gas or steam
(However, it is excepted when used for release a pressure of liquid or the setting value of rupture pressure is below 0.1MPag)

3. Main contents and Requirements of Obligation Safety Certification

- It shall be conducted a burst test under the same temperature as service condition
- When you apply for certification, it is required a certification of the same type separately if it is different to specification submitted
- It shall be certified, even if it is imported products

4. Relevant regulations

- Occupation safety and health acts
- Regulations for Occupation safety and health acts
- Implementing Regulations in Occupation safety and health acts
- Notification of Protection Device Obligation Safety Certification Criteria
- Notification for declaration of Safety Certification and Autonomy Safety Confirmation

5. Performance Criteria of Products

Burst test	Set Pressure	below 0.3MPag	0.3MPag and over
	Allowable range of rupture Pressure	±0.015MPag	±5%
Leak test	Division		Soak time
	Nominal diameter of rupture disc(mm)	50 and below	1 min
		above 50&100 and below	2 min
above 100	5 min		

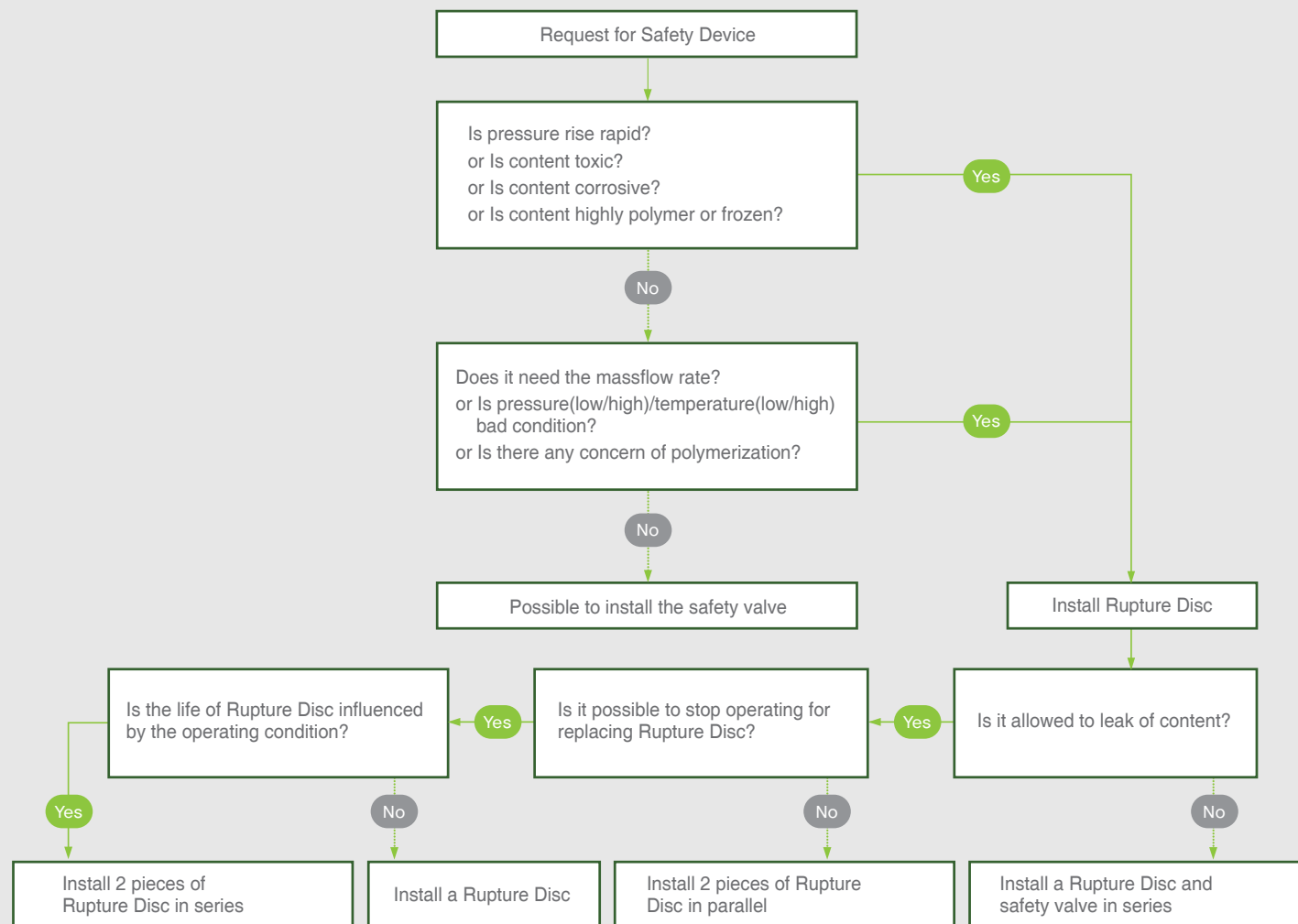
* It shall be conducted a leak test under 90% of set pressure
* In case of Flat/Slotted Type, it shall be conducted a leak test under 50% of set pressure

6. Classification and Notation of the KOSHA Certification Type

Division in accordance with structure	Rupture disc of dome type (C)	Single plate type (O) Composite type (C) Carved type or cutout type (S)					
	Rupture disc of inverted dome type(R)	Carved type or shearing type (S) Self-knife type (K)					
	Rupture disc of flat type(F)	Exchanger type graphite rupture disc (R) Monoblock type graphite rupture disc (M) Cutout type rupture disc (S)					
	Other type (X)	Rupture discs produced depend on the manufacturers which are different than above.					
Division in accordance with nominal diameter	Division of nominal diameter	I	II	III	IV	V	
	Range of nominal diameter(mm)	25 and below	above 25 & 50 and below	above 50 & 80 and below	above 80 & 100 and below	above 100	
Division in accordance with nominal pressure	Division of nominal pressure	1	3	5	10	21	22
	Range of rupture pressure(MPag)	1 and below	above 1&3 and below	above 3&5 and below	above 5&10 and below	above 10&21 and below	above 21
Notation of type	<div style="text-align: center;"> RS II 3 </div> <div style="text-align: center; margin-top: 5px;"> Structure Nominal Diameter Nominal pressure </div>						

RUPTURE DISC

SELECTION GUIDE



RUPTURE DISC

SELECTION MODEL

STEP 1. Check the pressure vessel and process operating specification (Process Data)

- Material properties of the fluids used
 - Gas or Vapor : Mol weight, Specific heat ratio, Compressibility coefficient
 - Liquid : Specific gravity, Viscosity
- State of the fluids used : Gas, Vapor, Steam, Liquid, etc.
- Operating condition : Static, Pulsation(Oscillation), Cycle, etc.
- MAWP(Maximum Allowable Working Pressure or Design Pressure) of pressure vessel
- Maximum operating pressure and temperature
- Required Capacity
- Set pressure and set temperature of Rupture Disc for rupture
- Back pressure and Vacuum pressure
- Material (Holder/Disc/Accessory)
- Connection(Flange/Fitting) specification
- Installation type of Rupture Disc : Primary, Secondary, Combination, External Fire
- Calculation of operating ratio :
 Operating ratio = Maximum operating pressure/Minimum rupture pressure × 100
 ※ Minimum rupture pressure = Set rupture pressure - Negative rupture tolerance

STEP 2. Model & Accessory (by FDC)

STEP 3. Calculation of size & rated flow capacity (by FDC)

RUPTURE DISC SIZING

ASME SECTION VIII DIV 1	
Dry saturated steam	$A = \frac{W_T}{51.5KP}$ <p>note) For pressure up to 1500psig apply the above equation, and for dry saturated steam pressures over 1500psig and up to 3200psig, the value of W_T, calculated by the above equation, shall be corrected by being multiplied by the following factor.</p> $\left(\frac{0.1906P-1000}{0.2292P-1061} \right)$
Gas/Air	$A = \frac{W_T}{CKP\sqrt{\frac{M}{T}}}$ (for air, C=356)
Liquid	$A = \frac{W_T}{2407 \cdot K \cdot \sqrt{(P-P_d) \cdot \omega}}$

KS B ISO 4126	
Gas/steam at critical flow	$A_o = 3.469 \frac{Q_m}{C \cdot \alpha} \sqrt{\frac{Z_o}{P_o}}$ <p>or</p> $A_o = \frac{Q_m}{C \cdot \alpha \cdot P_o} \sqrt{\frac{T_o \cdot Z_o}{M}}$ <p>For the homogenized wet steam of 90% or more dryness</p> $A_o = 3.469 \frac{Q_m \cdot \sqrt{x}}{C \cdot \alpha} \sqrt{\frac{Z_o}{P_o}}$
Gas/steam at subcritical flow	$A_o = 3.469 \frac{Q_m}{C \cdot K_b \cdot \alpha} \sqrt{\frac{Z_o}{P_o}}$ <p>or</p> $A_o = \frac{Q_m}{C \cdot K_b \cdot \alpha \cdot P_o} \sqrt{\frac{T_o \cdot Z_o}{M}}$
Liquid	$A_o = 0.621 \frac{W_T}{K_v \cdot \alpha \cdot \sqrt{\Delta P \cdot P}}$

- W_T Mass flow rate (lb/hr)
 - A Practical outlet area in opening rupture disc (in²)
 - P Whichever is greater in '(Set pressure × 1.10) + atmospheric pressure' or 'set pressure + 3psia + atmospheric pressure' (psia)
 - P_d Back pressure (pressure at outlet) (psia)
 - M Mol weight
 - T Absolute temperature at valve inlet, °F + 460 °F (R)
 - C Constant for gas or steam based on specific heat ratio ($k = C_p / C_v$)
- | k | C | k | C | k | C |
|------|-----|------|-----|------|-----|
| 1.00 | 315 | 1.26 | 343 | 1.52 | 366 |
| 1.02 | 318 | 1.28 | 345 | 1.54 | 368 |
| 1.04 | 320 | 1.30 | 347 | 1.56 | 369 |
| 1.06 | 322 | 1.32 | 349 | 1.58 | 371 |
| 1.08 | 324 | 1.34 | 351 | 1.60 | 372 |
| 1.10 | 327 | 1.36 | 352 | 1.62 | 374 |
| 1.12 | 329 | 1.38 | 354 | 1.64 | 376 |
| 1.14 | 331 | 1.40 | 356 | 1.66 | 377 |
| 1.16 | 333 | 1.42 | 358 | 1.68 | 379 |
| 1.18 | 335 | 1.44 | 359 | 1.70 | 380 |
| 1.20 | 337 | 1.46 | 361 | 2.00 | 400 |
| 1.22 | 339 | 1.48 | 363 | 2.20 | 412 |
| 1.24 | 341 | 1.50 | 364 | ... | ... |
- K Release coefficient (design coefficient, in general apply 0.62 for rupture disc and practical measure × 0.9 in real measurement, but it shall be less than 0.875.)
 - Z Compressibility coefficient related to P and T (if there is no available data, $Z=1.0$)
 - ω Specific weight of liquid under the condition for valve inlet (lb/ft³)

- A_o Minimum required flow cross sectional area (mm²)
 - Q_m Mass Flow rate (kg/h)
 - C Function for isentropic exponent k (Refer to table 1. Physical properties of gas)
- | k | C | k | C | k | C | k | C |
|------|------|-------|------|------|------|------|------|
| 0.50 | 1.81 | 1.001 | 2.40 | 1.26 | 2.61 | 1.52 | 2.78 |
| 0.60 | 1.96 | 1.02 | 2.41 | 1.28 | 2.62 | 1.54 | 2.79 |
| 0.70 | 2.08 | 1.04 | 2.43 | 1.30 | 2.63 | 1.56 | 2.80 |
| 0.80 | 2.20 | 1.06 | 2.45 | 1.32 | 2.65 | 1.58 | 2.82 |
| 0.82 | 2.22 | 1.08 | 2.46 | 1.34 | 2.66 | 1.60 | 2.83 |
| 0.84 | 2.24 | 1.10 | 2.48 | 1.36 | 2.68 | 1.62 | 2.84 |
| 0.86 | 2.26 | 1.12 | 2.50 | 1.38 | 2.69 | 1.64 | 2.85 |
| 0.88 | 2.28 | 1.14 | 2.51 | 1.40 | 2.70 | 1.66 | 2.86 |
| 0.90 | 2.30 | 1.16 | 2.53 | 1.42 | 2.72 | 1.68 | 2.87 |
| 0.92 | 2.32 | 1.18 | 2.55 | 1.44 | 2.73 | 1.70 | 2.89 |
| 0.94 | 2.34 | 1.20 | 2.56 | 1.46 | 2.74 | 1.80 | 2.94 |
| 0.96 | 2.36 | 1.22 | 2.58 | 1.48 | 2.76 | 2.00 | 3.04 |
| 0.98 | 2.38 | 1.24 | 2.59 | 1.50 | 2.77 | 2.20 | 3.13 |
- v_o Specific volume at practical release pressure and temperature (m³/kg)
 - P_o Release pressure (bar)
 - α Release coefficient (In general, apply 0.62)
 - T_o Release temperature (K)
 - Z_o Compressibility coefficient at practical release pressure and temperature (If there is no available data, $Z_o=1.0$)
 - M Mol weight
 - x Dryness of wet steam
 - K_b Viscosity correction factor related to Reynold's number(Re) If the liquid viscosity is less than that of water at 20°C, $k_v=1.0$ (Refer to Table 2. Capacity correction factor for viscosity)
 - K_v Correction factor for reduction in the theoretical capacity as increase of the back pressure in subcritical flow (Refer to table 3. Capacity correction factor for back pressure)
 - Re Reynold's number $Re = 0.3134 \frac{Q_m}{\mu \sqrt{A_o}}$
 - μ Viscosity of the liquid
 - ΔP differential pressure released through rupture disc ($\Delta P = P_o - P_b$) (bar)
 - P_b Back pressure (pressure at outlet) (psia)

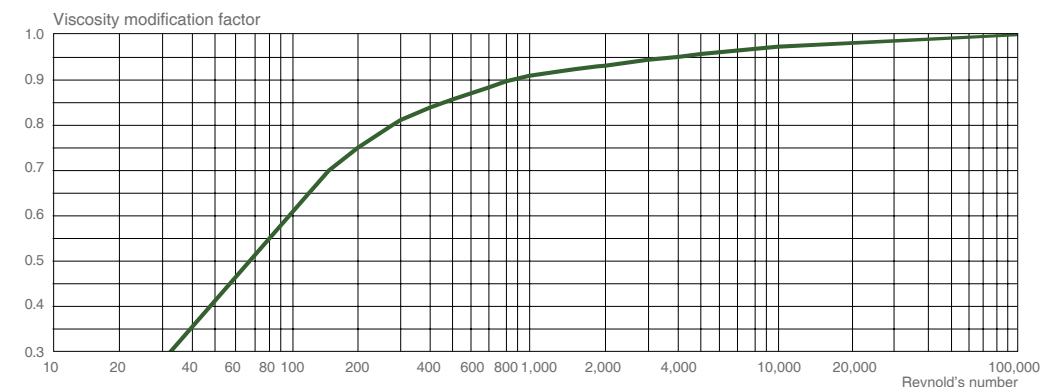
Table 1. Physical properties of gas

Name	Physical property	Formula	Mol weight(M)	Adiabatic constant(K)	Name	Physical property	Formula	Mol weight(M)	Adiabatic constant(k)
Acetylene		C ₂ H ₂	26.04	1.26	n-Hexane		n-C ₆ H ₁₄	86.18	1.06
Air		-	28.97	1.40	Hydrogen chloride		HCl	36.46	1.41
Ammonia		NH ₃	17.03	1.31	Hydrogen		H ₂	2.02	1.41
Argon		Ar	39.95	1.67	Hydrogen sulfide		H ₂ S	34.08	1.32
Butadiene		C ₄ H ₆	54.09	1.113	Dichloro difluoro methane		CCl ₂ F ₂	120.91	1.139
Benzene		C ₆ H ₆	78.12	1.12	Methane		CH ₄	16.04	1.31
iso-Butane		iso-C ₄ H ₁₀ or CH(CH ₃) ₃	58.12	1.10	Methyl alcohol		CH ₃ OH or CH ₄ O	32.04	1.20
n-Butane		n-C ₄ H ₁₀	58.12	1.09	Methyl chloride		CH ₃ Cl	50.49	1.20
Carbon disulfide		CS ₂	76.14	1.21	Nitrogen		N ₂	28.01	1.40
Carbon dioxide		CO ₂	44.01	1.29	Nitrogen dioxide		NO ₂	44.01	1.30
Carbon monoxide		CO	28.01	1.40	n-Nonane		n-CH ₃ (CH ₂) ₇ CH ₃ or C ₉ H ₂₀	128.26	1.04
Chlorine		Cl ₂	70.91	1.36	Oxygen		O ₂	32.00	1.40
Cyclohexane		C ₆ H ₁₂	84.16	1.09	n-Pentane		n-CH ₃ (CH ₂) ₃ CH ₃ or C ₅ H ₁₂	72.15	1.07
n-Decane		n-C ₁₀ H ₂₂	142.29	1.03	n-Propane		n-CH ₃ CH ₂ CH ₃ or C ₃ H ₈	44.10	1.13
Ethane		C ₂ H ₆	30.07	1.19	Water		H ₂ O	18.02	1.133
Ethyl alcohol		C ₂ H ₅ OH or C ₂ H ₆ O	46.07	-	Sulfur dioxide		SO ₂ or O ₂ S	64.06	1.29
Ethylene		C ₂ H ₄	28.05	1.24	Toluene		C ₆ H ₅ CH ₃ or C ₇ H ₈	92.15	1.09
Helium		He	4.00	1.66	Propylene		CH ₃ CH=CH ₂ or C ₃ H ₆	42.08	1.15
n-Heptane		n-CH ₃ (CH ₂) ₅ CH ₃ or C ₇ H ₁₆	100.21	1.05	Octane		CH ₃ (CH ₂) ₆ CH ₃ or C ₈ H ₁₈	114.00	1.05

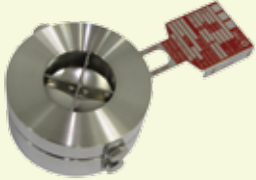
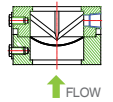
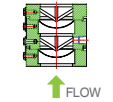
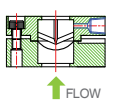
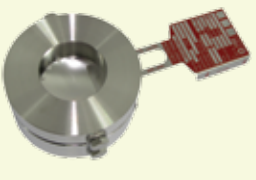
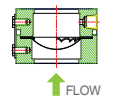
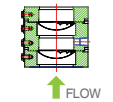
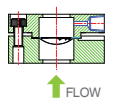
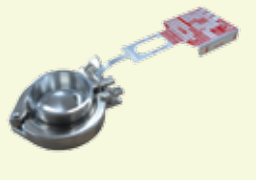
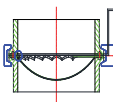

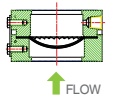
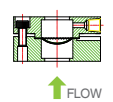
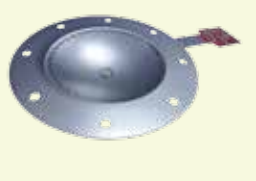

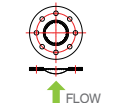

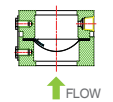
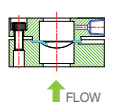
Table 2. Capacity correction factor for back pressure









$\frac{P_b}{P_o}$	Isentropic exponent(k)																		
	0.4	0.5	0.6	0.7	0.8	0.9	1.001	1.1	1.2	1.3	1.4	1.5	1.6	1.7	1.8	1.9	2.0	2.1	2.2
	Volume modification factor for back pressure																		
0.45																			
0.50																			
0.55																			
0.60																			
0.65																			
0.70																			
0.75																			
0.80	0.999	0.985	0.965	0.942	0.921	0.900	0.881	0.864	0.847	0.833	0.819	0.806	0.794	0.783	0.773	0.764	0.755	0.747	0.739
0.82	0.992	0.970	0.944	0.918	0.894	0.872	0.852	0.833	0.817	0.801	0.787	0.774	0.753	0.752	0.741	0.732	0.723	0.715	0.707
0.84	0.979	0.948	0.917	0.888	0.862	0.839	0.818	0.799	0.782	0.766	0.752	0.739	0.727	0.716	0.706	0.697	0.688	0.680	0.672
0.86	0.957	0.919	0.884	0.852	0.800	0.779	0.759	0.742	0.727	0.712	0.700	0.688	0.677	0.667	0.658	0.649	0.641	0.634	0.626
0.88	0.924	0.881	0.842	0.809	0.780	0.755	0.733	0.714	0.697	0.682	0.668	0.655	0.644	0.633	0.624	0.615	0.606	0.599	0.592
0.90	0.880	0.831	0.791	0.757	0.728	0.703	0.681	0.662	0.645	0.631	0.617	0.605	0.594	0.584	0.575	0.566	0.558	0.551	0.544
0.92	0.820	0.769	0.727	0.693	0.664	0.640	0.619	0.601	0.585	0.571	0.559	0.547	0.537	0.527	0.519	0.511	0.504	0.497	0.490
0.94	0.739	0.687	0.647	0.614	0.587	0.565	0.545	0.528	0.514	0.501	0.489	0.479	0.470	0.461	0.453	0.446	0.440	0.434	0.428
0.96	0.628	0.579	0.542	0.513	0.489	0.469	0.452	0.438	0.425	0.414	0.404	0.395	0.387	0.380	0.373	0.367	0.362	0.357	0.352
0.98	0.426	0.422	0.393	0.371	0.353	0.337	0.325	0.314	0.305	0.296	0.289	0.282	0.277	0.271	0.266	0.262	0.258	0.254	0.251
1.00	0.000	0.000	0.000	0.000	0.000	0.000	0.000	0.000	0.000	0.000	0.000	0.000	0.000	0.000	0.000	0.000	0.000	0.000	0.000

Table 3. Capacity correction factor for viscosity



PRODUCTS LIST

RUPTURE DISC				
	Model (Image)	Description	Holder or Connection Type	Drawing
REVERSE TYPE		Reverse Dome Knife Type	KS Insert Flat Seat Knife Blades Single Type	
			KD Insert Flat Seat Knife Blades Double Type	
			BK Bolted Flat Seat Knife Blades Single Type	
		Reverse Dome Shear Type	FS Insert Flat Seat Single Type	
			FD Insert Flat Seat Double Type	
			BF Bolted Flat Seat Single Type	
		Reverse Dome Shear Type for Ferrule	FERRULE Ferrule Connection Type	
		Reverse Dome Buckling Knife Type	BFS Insert Flat Seat Single Type for RBK	
			BBF Bolted Flat Seat Single Type for RBK	
		Reverse Dome Buckling Knife Type for Flange	RF Raised Face Flange Type	
			FF Flat Face Flange Type	
		Reverse Dome Scored Type	FS Insert Flat Seat Single Type	
			BF Bolted Flat Seat Single Type	

Size	Set. Pressure	Vacuum Support Required	Available Service Phase		Spark	Fragment	Max Operating Ratio
			Gas or Vapor	Liquid			
							
1/2" ~ 48" (15A ~ 1200A)	0.3 ~ 150 kg/cm ²	No	Yes	No	Yes	No	90%
1/4" ~ 4" (8A ~ 100A)							
1/2" ~ 24" (15A ~ 600A)	0.35 ~ 30 kg/cm ²	No	Yes	Yes	No	No	90%
1/4" ~ 4" (8A ~ 100A)							
1S~4S FERRULE	0.35 ~ 30 kg/cm ²	No	Yes	Yes	No	No	90%
1/2" ~ 36" (15A ~ 900A)	0.1 ~ 100 kg/cm ²	No	Yes	Yes	No	No	90%
1/4" ~ 4" (8A ~ 100A)							
1/2" ~ 36" (15A ~ 900A)	0.1 ~ 100 kg/cm ²	No	Yes	Yes	No	No	90%
1/2" ~ 24" (15A ~ 600A)	1.5 ~ 150 kg/cm ²	No	Yes	Yes	No	No	90%
1/4" ~ 4" (8A ~ 100A)							

PRODUCTS LIST

RUPTURE DISC				
	Model (Image)	Description	Holder or Connection Type	Drawing
FORWARD TYPE	KSRSF	Forward Dome Scored Type	FS Insert Flat Seat Single Type	
			BF Bolted Flat Seat Single Type	
	KSRST	Forward Dome Tension Flat Seat Type	FS Insert Flat Seat Single Type	
			SS Insert Sloped Seat Single Type	
	KSRCT	Forward Dome Tension Sloped Seat Type	SD Insert Sloped Seat Double Type	
			SS Insert Sloped Seat Single Type	
COMPOSITE DOME TYPE	KSRRC	Composite Dome Sloped Seat Type	SD Insert Sloped Seat Double Type	
			FS Insert Flat Seat Single Type	
	KSRRCH	Composite Dome Flat Seat Type	FD Insert Flat Seat Double Type	
			BF Bolted Flat Seat Single Type	
			RF Raised Face Flange Type	
	KSRRC	Composite Dome Flat Seat Type for Flange	FF Flat Face Flange Type	
			FERRULE Ferrule Connection Type	
	KSRRCFD	Composite Dome Flat Seat Double Acting Type for Ferrule	FERRULE Ferrule Connection Type	


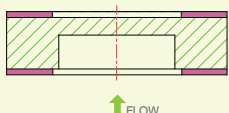

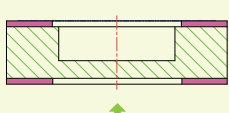

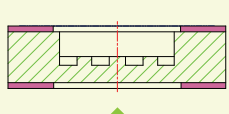



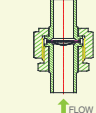
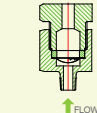
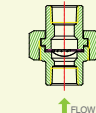



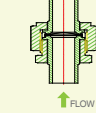
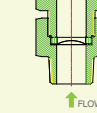
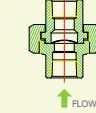



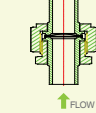
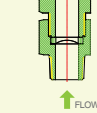
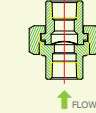



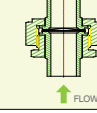
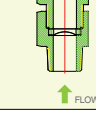
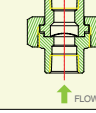
Size	Set. Pressure	Vacuum Support Required	Available Service Phase		Spark	Fragment	Max Operating Ratio
			Gas or Vapor	Liquid			
1/2" ~ 12" (15A ~ 300A)	5 ~ 700 kg/cm ²	No	Yes	Yes	No	No	80%
1/4" ~ 4" (8A ~ 100A)							
1/2" ~ 48" (15A ~ 1200A)	15 ~ 1,500 kg/cm ²	No	Yes	Yes	No	Yes	70%
1/2" ~ 40" (15A ~ 1000A)	15 ~ 1,500 kg/cm ²	Yes or No	Yes	Yes	No	Yes	70%
1/2" ~ 40" (15A ~ 1000A)	Teflon Seal	Yes	Yes	Yes	No	No	80%
	Metal Seal						
1/2" ~ 48" (15A ~ 1200A)	0.1 ~ 30 kg/cm ²	Yes	Yes	Yes	No	No	80%
	1.0 ~ 560 kg/cm ²						
1/4" ~ 4" (8A ~ 100A)	0.05 ~ 50 kg/cm ²	Yes	Yes	Yes	No	No	80%
1/2" ~ 52" (15A ~ 1300A)	0.05 ~ 50 kg/cm ²	Yes	Yes	Yes	No	No	80%
1S~4S FERRULE	0.3 ~ 15 kg/cm ²	Yes	Yes	Yes	No	No	80%
1S~4S FERRULE	0.3 ~ 15 kg/cm ²	Yes	Yes	Yes	No	No	80%









PRODUCTS LIST

RUPTURE DISC					
	Model (Image)	Description	Holder or Connection Type	Drawing	
COMPOSITE FLAT TYPE	KSROH	Composite Flat Type	H Insert Flat Seat Single Type for RO		
			B Bolted Flat Seat Single Type for RO		
	KSRO	Composite Flat Type for Flange	RF Raised Face Flange Type		
			FF Flat Face Flange Type		
	KSROF	Composite Flat Type for Ferrule	FERRULE Ferrule Connection Type		
	KSROHD	Composite Flat Double Acting Type	H Insert Flat Seat Single Type for RO		
			B Bolted Flat Seat Single Type for RO		
	KSROFD	Composite Flat Double Acting Type for Ferrule	FERRULE Ferrule Connection Type		
	ULTRA LOW PRESSURE TYPE	KSRRLL	Reverse Dome Knife Type - LP	LS Insert Flat Seat Single Type for RRL & RRLD	
				LVS Insert Flat Seat Single Type for RRL & RRLD(Vacuum)	
KSRRLLD		Reverse Dome Knife Double Acting Type - LP	LS Insert Flat Seat Single Type for RRL & RRLD		
			LVS Insert Flat Seat Single Type for RRL & RRLD(Vacuum)		
KSROL		Composite Flat Type for Flange - LP	RF Raised Face Flange Type		
			FF Flat Face Flange Type		







Size	Set. Pressure	Vacuum Support Required	Available Service Phase		Spark	Fragment	Max Operating Ratio
			Gas or Vapor	Liquid			
1/2" ~ 48" (15A ~ 1200A)	0.05 ~ 35 kg/cm ²	Yes	Yes	Yes	No	No	50%
1/4" ~ 4" (8A ~ 100A)							
1/2" ~ 72" (15A ~ 1800A)	0.05 ~ 35 kg/cm ²	Yes	Yes	Yes	No	No	50%
1S~4S FREEULE	0.05 ~ 15 kg/cm ²	Yes	Yes	Yes	No	No	50%
1/2" ~ 48" (15A ~ 1200A)	0.05 ~ 15 kg/cm ²	Yes	Yes	Yes	No	No	50%
1/4" ~ 4" (8A ~ 100A)							
1S~4S FREEULE	0.05 ~ 15 kg/cm ²	Yes	Yes	Yes	No	No	50%
1/2" ~ 10" (15A ~ 250A)	0.01 ~ 1.0 kg/cm ² (100 ~ 10,000 mmAq)	Yes	Yes	No	No	No	50%
1/2" ~ 10" (15A ~ 250A)	0.01 ~ 1.0 kg/cm ² (100 ~ 10,000 mmAq)	Yes	Yes	No	No	No	50%
4" ~ 32" (100A ~ 800A)	0.01 ~ 0.15 kg/cm ² (100 ~ 1,500 mmAq)	Yes	Yes	No	No	No	50%


PRODUCTS LIST

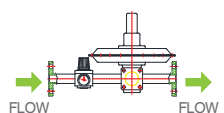
RUPTURE DISC					
Model	Description	Connection Type			
KSRGM 	Drawing 	Mono Type	Inserted between Flange		
KSRGI 	Drawing 	Inverted Type	Inserted between Flange		
KSRGD 	Drawing 	Double Acting Type	Inserted between Flange		
			VCR	PLUG	UNION
Image	KSRRKV 	KSRRKP 	KSRRKU 	Reverse Dome Shear Type	
Drawing					
Image	KSRSFV 	KSRSFP 	KSRSFU 	Forward Dome Scored Type	
Drawing				Standard VCR Connector	MFR Standard Screwed Connector
Image	KSRSTV 	KSRSTP 	KSRSTU 	In/Outlet Standard Connector	Inlet Screwed Male or Female
Drawing					Outlet Screwed Male or Female
Image	KSRRCV 	KSRRCP 	KSRRCU 	Composite Dome Flat Seat Type	
Drawing					









Model	Size	Set. Pressure	Vacuum Support Required	Available Service Phase		Spark	Fragment	Max Operating Ratio
				Gas or Vapor	Liquid			
								
KSRGM	1/2" ~ 24"	0.017 ~ 10 kg/cm ²	Yes	Yes	Yes	No	Yes	90%
KSRGI	1/2" ~ 24"	0.017 ~ above 70 kg/cm ²	Yes	Yes	Yes	No	Yes	90%
KSRGD	1-1/2" ~ 24"	0.017 ~ 0.49 kg/cm ²	Yes	Yes	Yes	No	Yes	90%
KSRRKV	1/4" ~ 1" (8A ~ 25A)	4 ~ 50 kg/cm ²	No	Yes	Yes	No	No	90%
KSRRKP KSRRKU	1/4" ~ 2" (8A ~ 50A)		No	Yes	Yes	No	No	90%
KSRSFV	1/4" ~ 1" (8A ~ 25A)	15 ~ 3,500 kg/cm ²	No	Yes	Yes	No	No	90%
KSRSFP KSRSFU	1/4" ~ 2" (8A ~ 50A)		No	Yes	Yes	No	No	90%
KSRSTV	1/4" ~ 1" (8A ~ 25A)	15 ~ 3,500 kg/cm ²	No	Yes	Yes	No	Yes	70%
KSRSTP KSRSTU	1/4" ~ 2" (8A ~ 50A)		No	Yes	Yes	No	Yes	70%
KSRRCV	1/4" ~ 1" (8A ~ 25A)	1.5 ~ 50 kg/cm ²	Yes	Yes	Yes	No	No	80%
KSRRCP KSRRCU	1/4" ~ 2" (8A ~ 50A)		Yes	Yes	Yes	No	No	80%









PRODUCTS LIST









EXPLOSION PANEL	Model (Image)	Description	Connection Type	Drawing
	KSRPR	<ul style="list-style-type: none"> Round Flat Type Round Dome Type 	RF	
			FF	
	KSRPS	<ul style="list-style-type: none"> Rectangular Flat Type Rectangular Dome Type 	FF	
	FF			

EMERGENCY RELIEF HATCH	Model (Image)	Description	Connection Type	Drawing
	KSRH		Rupture Rod & Seal Type	Standard Flange

N ₂ BLANKETING SYSTEM	Model (Image)	Description	Connection Type	Drawing
	KSBKL	Single Operating Type	Standard Flange or Screwed Piping	
				
	KSBKT	Pilot Operating Type	Standard Flange or Screwed Piping	
				
KSBKS	Pilot Operating Type	Standard Flange or Screwed Piping		

Size	Set. Pressure	Vacuum Support Required	Available Service Phase		Spark	Fragment	Max Operating Ratio
			Gas or Vapor	Liquid			
							
Max. Ø3600	0.01 ~ 0.5 kg/cm ² (100 ~ 5,000 mmAq)	Yes	Yes	No	No	No	50%
1400 X 2000 mm	0.01 ~ 0.5 kg/cm ² (100 ~ 5,000 mmAq)	Yes	Yes	No	No	No	50%

Size	Set. Pressure	Vacuum Support Required	Available Service Phase		Spark	Fragment	Max Operating Ratio
			Gas or Vapor	Liquid			
							
18" ~ 36" (450A ~ 900A)	150 ~ 5,000 mmAq	Yes	Yes	N/A	No	No	80%

Size	Set. Pressure	Vacuum Support Required	Available Service Phase		Spark	Fragment	Max Operating Ratio
			Gas or Vapor	Liquid			
							
1/2" ~ 2"	12.5 ~ 8,000 mmAq	N/A	Yes	No	N/A	N/A	N/A
1/2" ~ 2"	20 ~ 8,000 mmAq	N/A	Yes	No	N/A	N/A	N/A
1" ~ 2"	20 ~ 8,000 mmAq	N/A	Yes	No	N/A	N/A	N/A

REVERSE TYPE



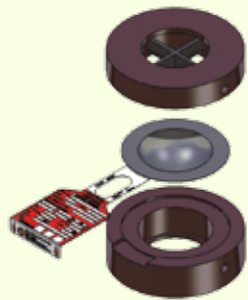
KSRR



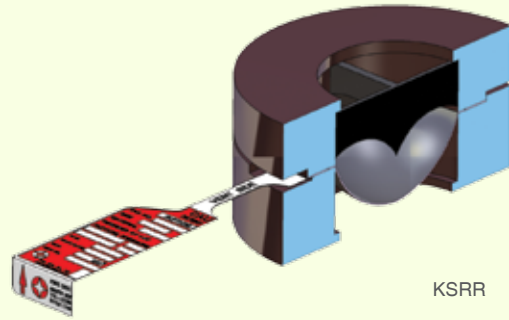
KSRR

KSRR (Reverse Dome Knife Type)

- Reversal structure ruptured by knife blade attached to upper holder while dome is inverted
- Mounted into FDC standard holder
- Ideal for counterpressure, vacuum and pulsation conditions
- Withstands full vacuum without vacuum support



KSRR



KSRR



KSRBKH



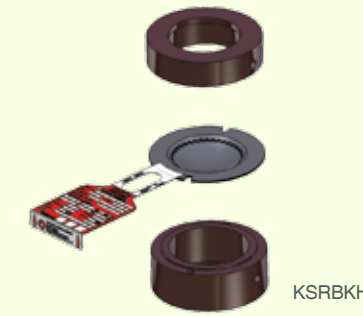
KSRBKH

KSRBKH (Reverse Dome Buckling Knife Type)

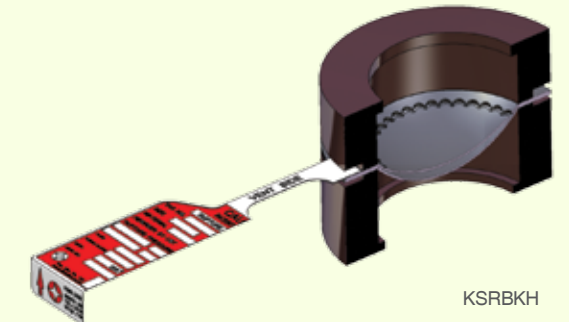
- Ruptured while dome is sheared by Knife of Control Disc
- Mounted into FDC standard holder
- It consists of Control Disc and Seal Disc
- Easy to handle with strong impact resistance
- Precise rupture performance and excellent reliability
- Ideal for counterpressure, vacuum and pulsation conditions
- Withstands full vacuum without vacuum support

KSRBK (Reverse Dome Buckling Knife Type for Flange)

- Identical disc type with KSRBKH, but mounted directly between flanges without holder



KSRBKH



KSRBKH



KSRRK



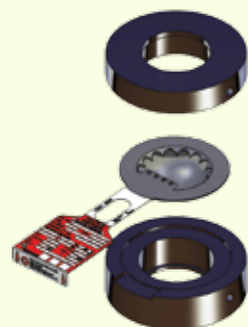
KSRRK

KSRRK (Reverse Dome Shear Type)

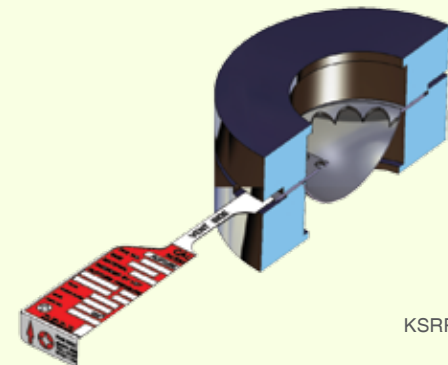
- Shearing structure ruptured by knife ring attached to disc while dome is inverted
- Mounted into FDC standard holder
- It is integrated with Disc and Knife
- Easier to handle than KSRR
- Ideal for counterpressure, vacuum and pulsation conditions
- Withstands full vacuum without vacuum support

KSRRKF (Reverse Dome Shear Type for Ferrule)

- KSRRK type disc designed for installation between ferrules



KSRRK



KSRRK



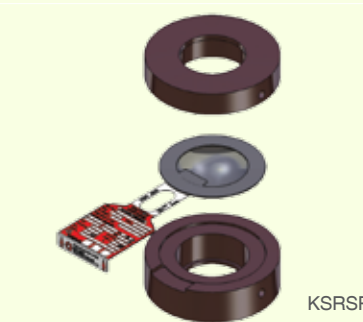
KSRSR



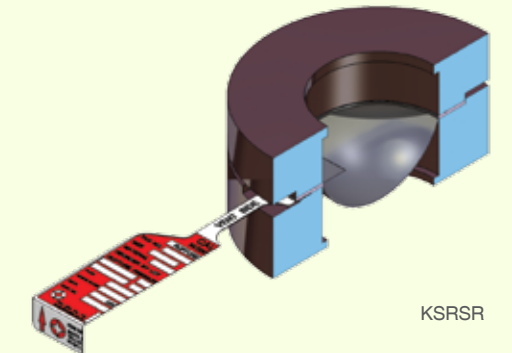
KSRSR

KSRSR (Reverse Dome Scored Type)

- Carved structure ruptured while inverted along with Scored Line processed precisely
- Mounted into FDC standard holder
- Designed for high pressure application
- Ideal for counterpressure, vacuum and pulsation conditions
- Withstands full vacuum without vacuum support



KSRSR



KSRSR

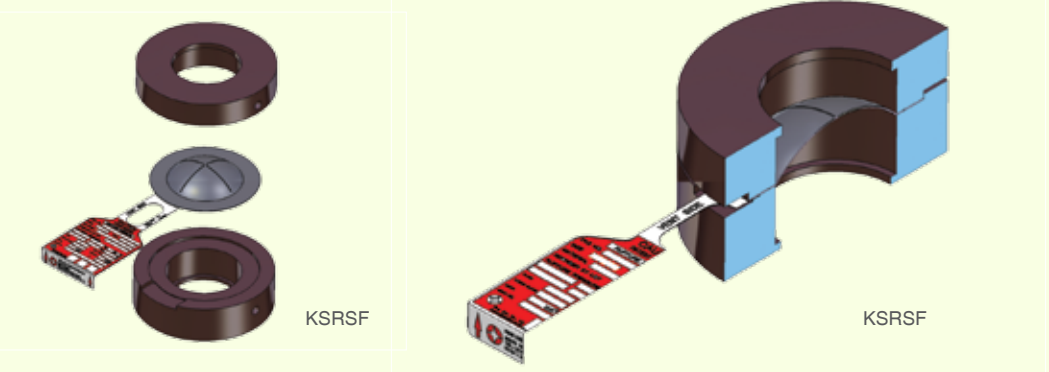


FORWARD TYPE



KRSRF (Forward Dome Scored Type)

- Carved structure with Scored Damage processed precisely ruptured by tension
- Mounted into FDC standard holder
- Designed for high pressure application
- Ideal for counterpressure, vacuum and pulsation conditions
- Withstands full vacuum without vacuum support

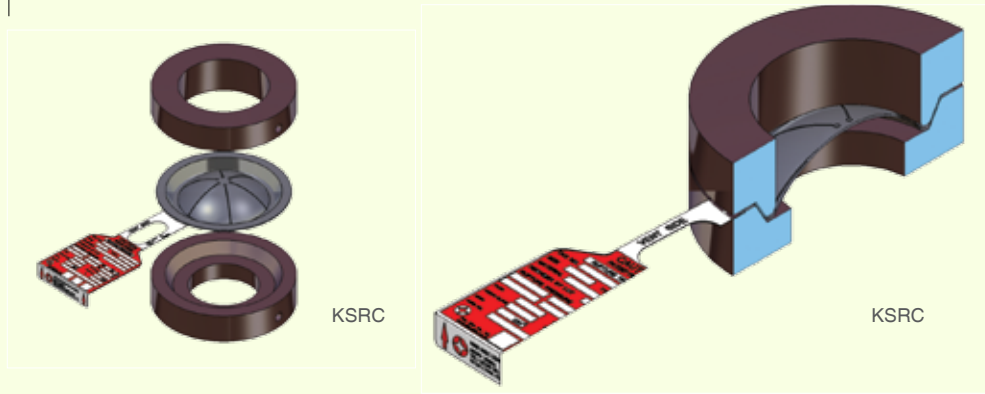


COMPOSITE DOME TYPE



KSRC (Composite Dome Sloped Seat Type)

- Composite/Dome structure ruptured by slit processed on Top disc
- Mounted into FDC standard holder
- It consists of Top disc, Seal disc and Vacuum disc
- Suitable for liquid or steam media environments
- Teflon or Metal seal is available
- Ideal for counterpressure, vacuum and pulsation conditions
- If required, vacuum support is available

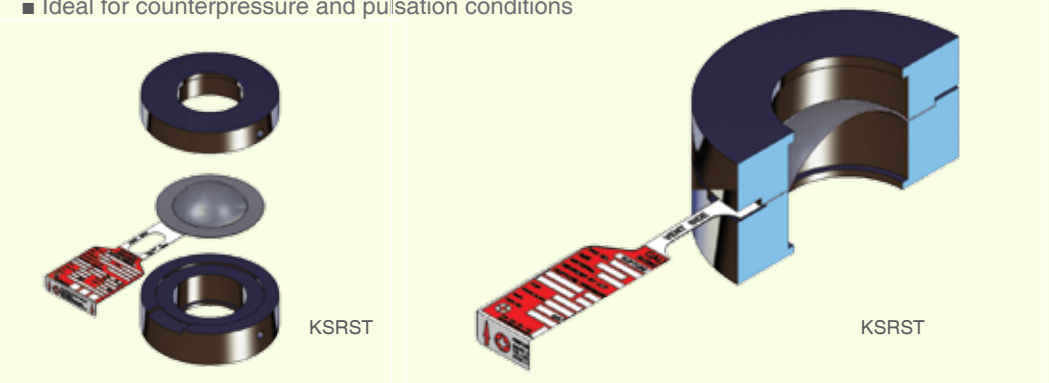


KSRST (Forward Dome Tension Flat Seat Type)

- Structure with disc ruptured by tensile strength
- Mounted into FDC standard holder
- Precise rupture performance and excellent reliability
- Designed for high/ultra high pressure application

KSRCT (Forward Dome Tension Sloped Seat Type)

- Consists of top disc, support disc and guide ring
- Identical feature with KSRST, but seat type is different
- mounted into FDC standard holder
- Ideal for counterpressure and pulsation conditions



KSRRCH (Composite Dome Flat Seat Type)

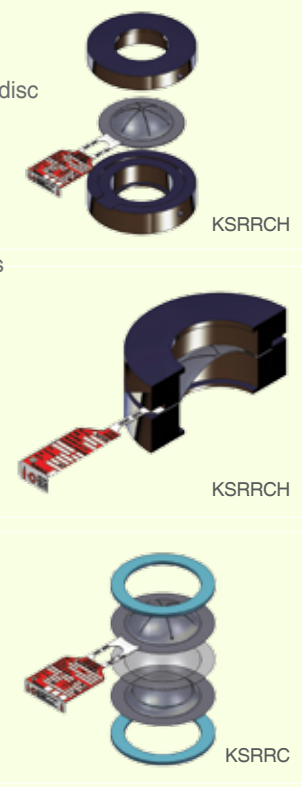
- Composite/Dome structure ruptured by slit processed on Top disc
- Mounted into FDC standard holder
- It consists of Top disc, Seal disc and Vacuum disc
- Suitable for liquid or steam media environments
- Teflon or Metal seal is available
- Ideal for counterpressure, vacuum and pulsation conditions
- If required, vacuum support is available

KSRRCF (Composite Dome Flat Seat Type for Ferrule)

- KSRRCF type disc designed for installation between ferrules

KSRRCFD (Composite Dome Flat Seat Double Acting Type for Ferrule)

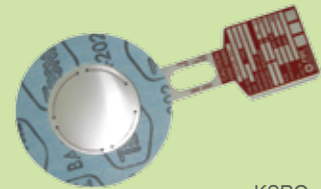
- KSRRCF type disc burst in one direction for overpressure and in the opposite direction for vacuum



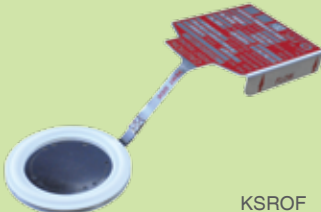
COMPOSITE FLAT TYPE



KSROH



KSRO



KSROF



KSROHD



KSROFD

KSROH (Composite Flat Type)

- Composite/Flat structure ruptured by slit processed on Top disc
- Mounted into FDC standard holder
- It consists of Top disc, Seal disc and Vacuum disc
- Teflon or Metal seal is available
- Vulnerability to pulsation conditions
- If required, vacuum support is available

KSRO (Composite Flat Type for Flange)

- Identical disc type with KSROH, but mounted directly between flanges without holder

KSROF (Composite Flat Type for Ferrule)

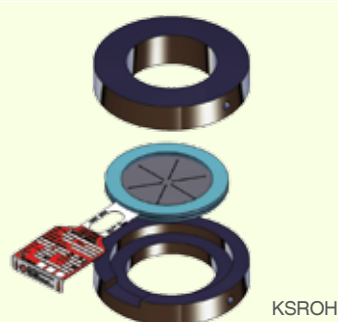
- KSRO type disc designed for installation between ferrules

KSROHD (Composite Flat Double Acting Type)

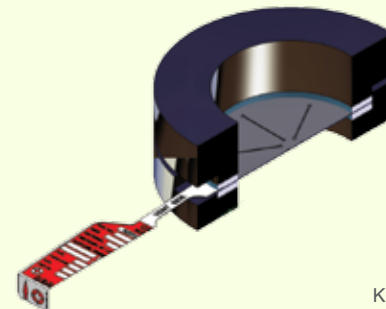
- KSROH type disc burst in one direction for overpressure and in the opposite direction for vacuum

KSROFD (Composite Flat Double Acting Type for Ferrule)

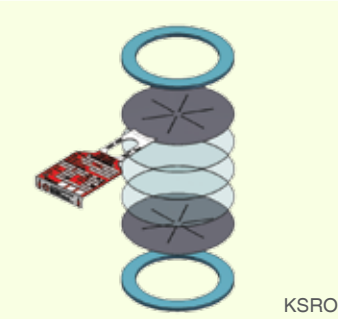
- KSROF type disc burst in one direction for overpressure and in the opposite direction for vacuum



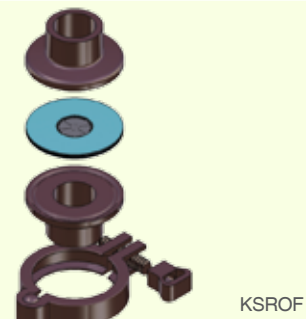
KSROH



KSROH

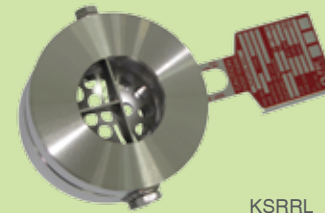


KSRO



KSROF

ULTRA LOW PRESSURE TYPE



KSRRL



KSRRLD

KSRRL (Reverse Dome Knife Type - LP)

- Designed for ultra low pressure with minimum 100mmAq of set pressure
- Reversal structure ruptured by knife blade attached upper holder while dome is inverted
- Mounted into FDC standard holder
- It consists of Support disc, Disc seal and Vacuum support

KSRRLD (Reverse Dome Knife Double Acting Type - LP)

- KSRRL type disc burst in one direction for overpressure and in the other direction for vacuum

KSROL (Composite Flat Type for Flange - LP)

- It is used for ultra low pressure with minimum 100mmAq of set pressure
- Composite/Flat structure ruptured by slit processed on Setting disc
- It consists of Top disc, Setting disc, Seal disc and Vacuum disc
- Teflon or Metal seal is available

FITTING CONNECTION TYPE



VCR



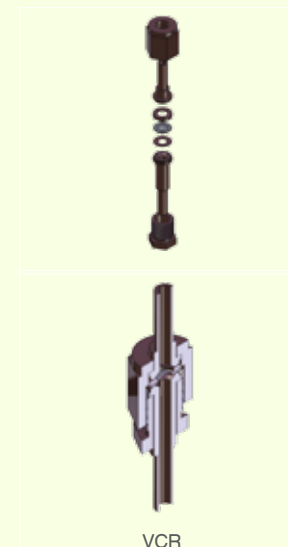
PLUG



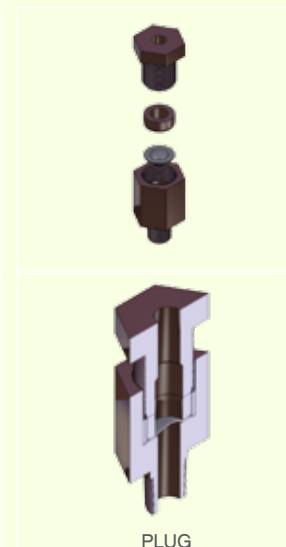
UNION



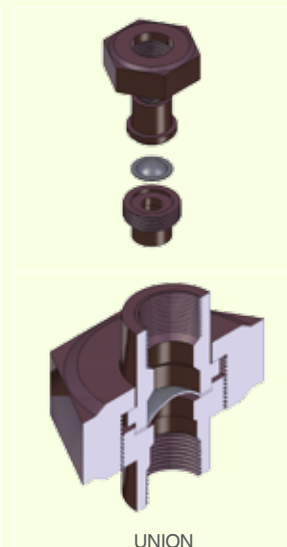
- KSRRKV / KSRRKP / KSRRKU** (Reverse Dome Shear Type for VCR/PLUG/UNION)
 - KSRRK disc for fitting connection
- KSRSFV / KSRSFP / KSRSFU** (Forward Dome Scored Type for VCR/PLUG/UNION)
 - KSRSF disc for fitting connection
- KSRSTV / KSRSTP / KSRSTU** (Forward Dome Tension Type for VCR/PLUG/UNION)
 - KSRST disc for fitting connection
- KSRRCV / KSRRCP / KSRRCU** (Composite Dome Shear Type for VCR/PLUG/UNION)
 - KSRRC disc for fitting connection



VCR



PLUG



UNION

GRAPHITE DISC

GRAPHITE DISC

GRAPHITE DISC Features

- Made from a single piece of graphite which is impregnated with phenolic resin
- Easy to install and maintain
- Installed directly between standard flanges without holders
- Excellent corrosion resistance

KSRGM

- Ideal for low and intermediate burst ratings
- Counterboard side of the disc contacts the process media
- In case of vacuum condition, vacuum supports are available for ratings below 25 psig
- Insulated Units are supplied armored with required insulation and gaskets for service above 221°C to 371°C
- Armor is required for temperatures above 170°C

KSRGI

- Ideal for higher burst ratings
- Flat surface of the disc contacts the process media
- Armor is required for temperatures above 170°C
- TFE liner is available to extend corrosion resistance

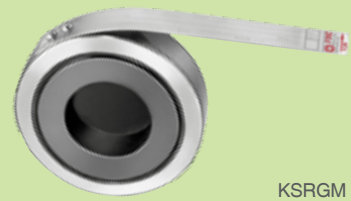
KSRGD

- Setting two different pressures in the opposite directions (Double Acting Type)
- Optional liner is available to extend corrosion resistance
- Armor is required for temperatures above 170°C

Specification

Division	KSRGM	KSRGI	KSRGD
Standard	ASME Code sec VIII KS B ISO 4126, API RP520, KOSHA CODE, FDC standard		
Size	1/2" ~ 24"		1-1/2" ~ 24"
Set. Pressure	0.017 ~ 10 kg/cm ²	0.017 ~ above 70 kg/cm ²	0.017 ~ 0.49 kg/cm ²
Temperature	-179 ~ 371 °C		-179 ~ 221°C
Material	Graphite		
Fragment	Yes		
Process Media	Gas, Vapor, Liquid		
Max. Operating Ratio	90%		
Spark	NO		
Option	Fluoropolymer sintered, Vacuum Support, Insulation, Armor, Gasket,	Fluoropolymer sintered, Armor, Liner, External Type Vacuum Support, Gasket	Fluoropolymer sintered, Armor, Liner, Gasket

- Contact FDC for Set. Pressure details corresponding to each size



KSRGM



KSRGI



KSRGD

BURST SENSOR

BURST SENSOR

BURST SENSOR Features

- The Burst Sensor is a device indicating rupture disc activation.
- Upon rupture of the disc, alarm circuit is opened by the flowing media, and alarm system warns immediately.
- FDC Burst Sensor is usable over a wide range of temperatures and simply replaced along with the rupture disc.

KSBS-A

- Installed on the vent side of Rupture Disc Holder.
- Consists of alarm strip combined with copper conductors and gasket attached on each side.
- Upon rupture of disc, sensor film is cut. As result of this, the flow of current is cut off and it instantaneously notifies rupture disc activation.
- Gasket Material: Non-asbestos, Teflon and Graphite etc.

- Electrical Specifications (Material with 1.5 meter extension cable)

Ui	Ii	Pi	Ci	Li
25,5 V	90 mA	0,63 W	0,01 nF	1,66 μH

KSBS-B

- Integrated directly into the rupture disc on the vent side
- Consists of alarm strip combined with copper conductors
- Upon rupture of disc, sensor film is cut. As result of this, the flow of current is cut off and it instantaneously notifies rupture disc activation.

- Electrical Specifications (Material with 1.5 meter extension cable)

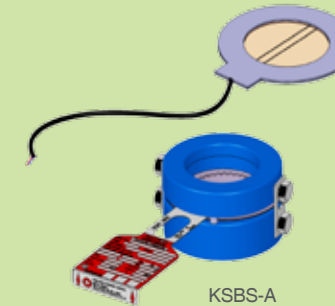
Ui	Ii	Pi	Ci	Li
25,5 V	90 mA	0,63 W	0,01 nF	1,66 μH

KSBS-C

- Integrated directly into the rupture disc on the vent side.
- Upon rupture of disc, sensor cable is cut. As result of this, the flow of current is cut off and it instantaneously notifies rupture disc activation.

- Electrical Specifications (Material with 1.5 meter extension cable)

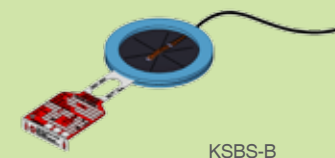
Ui	Ii	Pi	Ci	Li
25,5 V	90 mA	0,63 W	0,02 nF	1,24 μH



KSBS-A



- GAS II 2G EX ib IIC T6 Gb
- DUST II 2D EX ib IIIC T135°C Db



KSBS-B



- GAS II 2G EX ib IIC T6 Gb
- DUST II 2D EX ib IIIC T135°C Db



KSBS-C



- GAS II 2G EX ib IIC T6 Gb
- DUST II 2D EX ib IIIC T135°C Db

ACCESSORY

Pressure Gauge(P/G)	A measurement device which determines the pressure
Pressure Switch(P/S)	A device designed to monitor a process pressure and provide an output when a set pressure is reached
Excess Flow Valve(E.F.V)	A kind of check valve maintaining atmospheric pressure in the space between the rupture disc and the relief valve with a pressure gauge
Nipple, Tee, Plug, Reducer	Fitting for installation of P/G, P/S and E.F.V.
Stud Bolt & Nut	Tightening bolt & nut for In/Out Flange
Eye Bolt	A bolt which is attached to heavy holder so that ropes or cables are tied to it
Gasket	Sealing of In/Out Flange mating surface
J-Hook	J-shaped hooks installed at lower Holder
Jack Screw	It provides safe and easy installation of rupture discs by separating Inlet/Outlet flanges
Burst Sensor	A burst indicator providing instantaneous notification of rupture disc activation
Junction Box	Terminal box for connecting shield cable of burst sensor
Rain Hood	It protects Rupture Disc against foreign objects or rain inflow by installed onto downstream of the Rupture Disc exposed to the atmosphere
Heat Shield	Heat shield such as cerakwool and aerogel is attached to disc and helps disc to withstand the high temperature



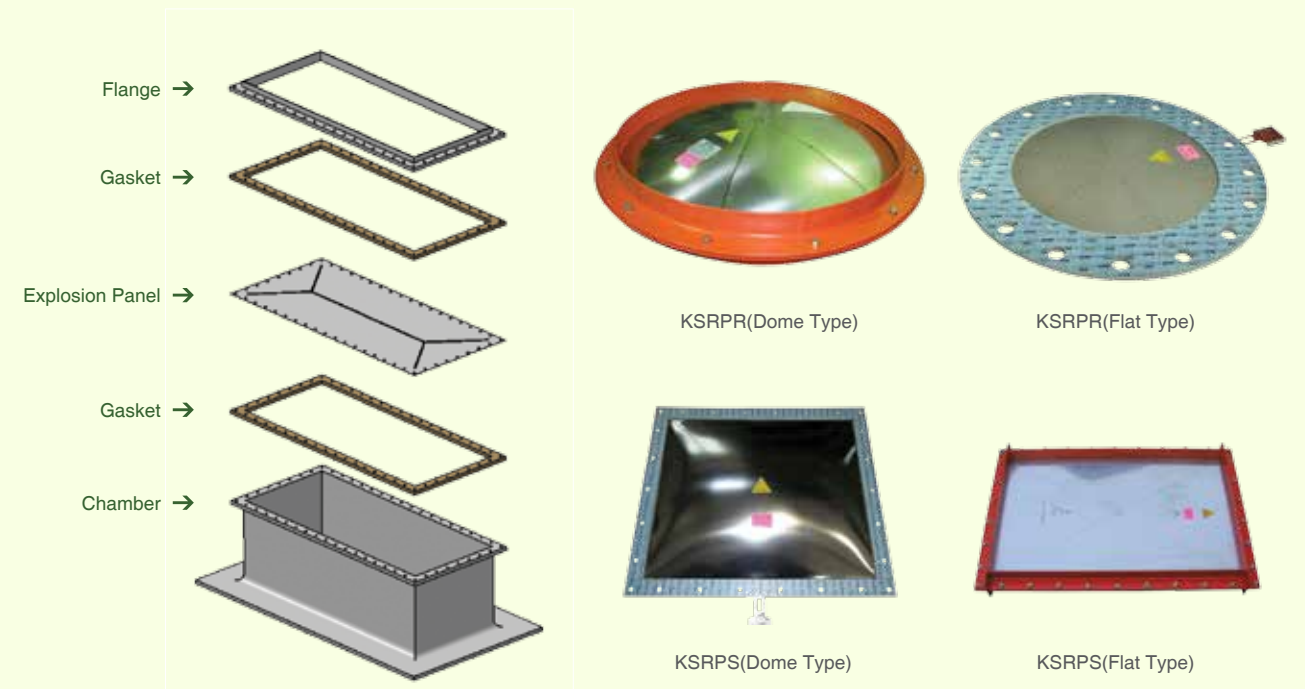
EXPLOSION PANEL

Explosion Panel Introduction

- Safety device for preventing equipments from damage by instantaneous release of pressure and flame which were increased in the process of deflagration before gas, powder, dust and other mixtures are progressed into detonation by ignition

Explosion Panel Features

- **Applicable equipment** : Silo, Bag Filter, RTO, Bucket Elevator, Duct, Hopper, etc
- **Fluids** : Dust, Gas, Powder, Mixture
- **Code** : NFPA 68, KOSHA CODE
- **Advantages**
 - Prompt operating in low pressure and reduction of pressure
 - Fast release to minimize the damage caused by expansion gas
 - Design for prevention of leakage and fragments
 - Easy to replace and low maintenance cost
 - Possible to select any quantity and installation location depending on the vessel size and the type of contents



N2 BLANKETING SYSTEM

What is the N2 Blanketing System?

- Control device to maintain a constant pressure state by injecting N2 gas, that is, inert gas to upper room of the tank

Functions of N2 gas

- It reduces evaporation loss of the products to minimize the formation of vapor in the tank
- It removes explosive factors by controlling hazardous gas ingredients such as oxygen from vapor space in the tank
- It prevents products from damage by inflow of unnecessary moisture and air
- It prevents explosion by controlling electrostatic spark
- It promotes delivery rate of product by decreasing of discharging time of product
- It prevents the modification of tank by controlling vacuum in the tank

Type

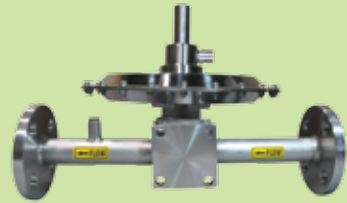
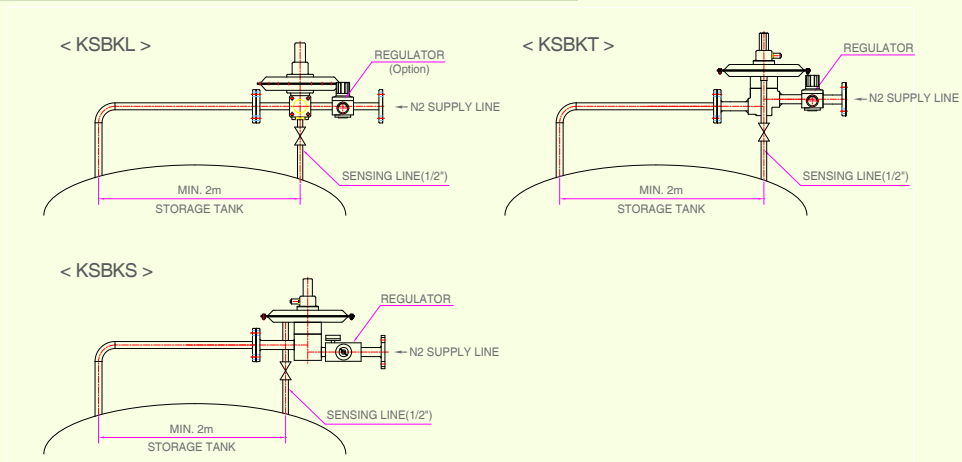
- KSBKL (Low capacity)
- KSBKT (High capacity)
- KSBKS (Ultra high capacity)

Flow Capacity (Rated Flow)

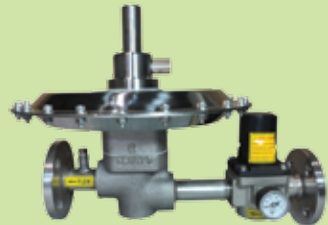
[Measure : Nm³/h]

Model	Inlet Pressure						
	1 barg	2 barg	3 barg	4 barg	5 barg	6 barg	7 barg
KSBKL	64.7	105.2	145.2	184.7	223.6	262	299.8
KSBKT	240.6	367.4	493.6	625.3	744.6	869.4	993.9
KSBKS	871.3	1316.9	1650.9	1891.8	2058	2168	2240.3

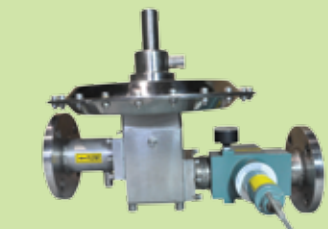
Installation- Layout



KSBKL



KSBKT



KSBKS

EMERGENCY RELIEF HATCH - KSRH

EMERGENCY RELIEF HATCH - KSRH

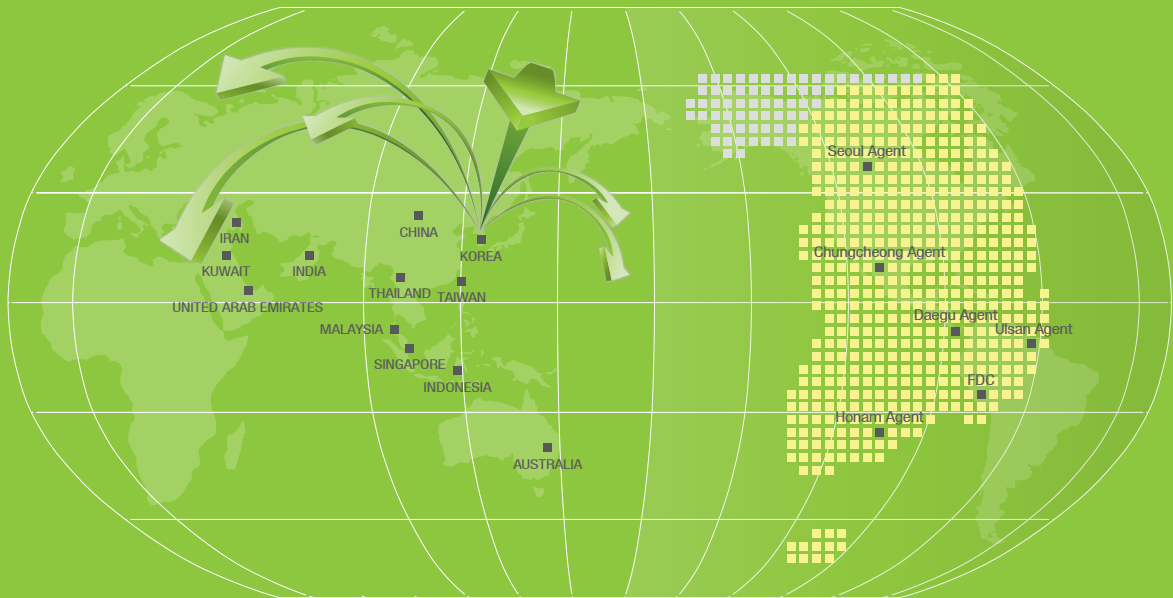
- A device for release the internal pressure with opening the cover by rupturing of tension rod when overpressure reaches more than allowable operating pressure by increasing of internal pressure of vessel
- Unlike general emergency venting device, it sets the required pressure by tension rod, and because it uses sealing diaphragm, it has excellent sealing capacity compared with the existing weight type, oil seal type and spring type
- Also, in case of oil seal type it has somewhat lower reliability because its setting pressure is not uniform by the difference of oil viscosity depending on temperature

Features

- Excellent sealing capacity and any leakage is not permitted
- Diaphragm is built in for sealing
- Available on LNG ship and ground tank mainly
- Possible to lower set pressure
- Maintenance cost is low because it is possible to reset by replacing some parts after rupturing



FDC NETWORK



Seoul Agent

36-19, Byeollaejungang-ro, Namyangju-si,
Gyeonggi-do, Korea
TEL. 031-514-9311 / FAX. 031-529-9313
E-mail : fine0117@nate.com

Ulsan Agent

#501, Industrial Tool Market, 24, Galbat-ro, Nam-gu,
Ulsan, Korea
TEL. 055-267-9002 / FAX. 055-267-9005
E-mail : kopro@kopro.co.kr

U.A.E. Agent (Gulf Commercial Group Establishment)

Abu Dhabi - Salam Street Shaheen Tower - Suit 101.
P.O.Box 43044, Abu Dhabi, United Arab Emirates
TEL. +971 2 644 2999
E-mail : sales@gcg-es.com

Honam Agent

249-7, Museon-ro, Yeosu-si, Jeollanam-do,
Korea
TEL. 061-691-9223 / FAX. 061-691-9224
E-mail : power5950@hanmail.net

Joongbu Agent

80, Gwanjeobuk-ro, Seo-gu, Daejeon,
302-904, Korea
TEL. 042-541-8988 / FAX. 042-367-8989
E-mail : jhkim@junplant.com

Kuwait Agent (ARABI ENERTECH K.S.C)

PO Box 9831, Ahmadi, 61009, Kuwait
TEL. +965-23986083 / FAX. +965-23982497
E-mail : enertech@arabienertech.com

Daegu Agent

#25-26, 16, Yutongdanji-ro, Buk-gu, Daegu, Korea
TEL. 053-604-1400 / FAX. 053-604-1405
E-mail : byun3860@naver.com



■ Head Office and a first Plant

99, Seobu-ro 1293beon-gil, Juchon-myeon, Gimhae-si,
Gyeongsangnam-do, Korea
TEL. 055-337-0852 / FAX. 055-337-0858
E-mail : finedisc@finedisc.co.kr

■ A second Plant

82-2, Seobu-ro 1499beon-gil, Juchon-myeon, Gimhae-si,
Gyeongsangnam-do, Korea

